

SHARP 108" LCD



SHARP 108" LCD MOUNTED ON MOTORISED SCREENLIFTER



MOTORISED SCREENLIFTER UNIT FOR SHARP 108" LCD

DISPLAY

Screen Size	108"
Resolution	1920 x 1080
Aspect Ratio	16 : 9
Brightness	400 cd/m ²
Contrast Ratio	1200 : 1
Response Time	6ms
Viewing Angle	176°

SIGNAL INPUT

PC	DVI-I
Video	HDMI, Component, S- Video, Composite
Network	N/A

POWER

Power Consumption	1130W
Standby Power	0.8W

FEATURES

Multimedia Speakers	Stereo Speaker Out, 15W
Mac Compatibility	Yes
Wall Mount	N/A
Cabinet Colour	Piano Black
Accessories	Remote Controller, Operating Instructions

DIMENSIONS

Product Dimensions (with Stand)	N/A
Product Dimensions (without Stand)	2572mm x 1550mm x 204mm
Shipping Dimensions (in Delivery Crate)	2755mm x 2020mm x 745mm

WEIGHT

Product Weight	195kg
Shipping Weight	317kg

STAND

Standard	Screenlifter
Optional	N/A

SHARP 108" LCD WITH SCREENLIFTER

SCREENLIFTER FLIGHTCASE

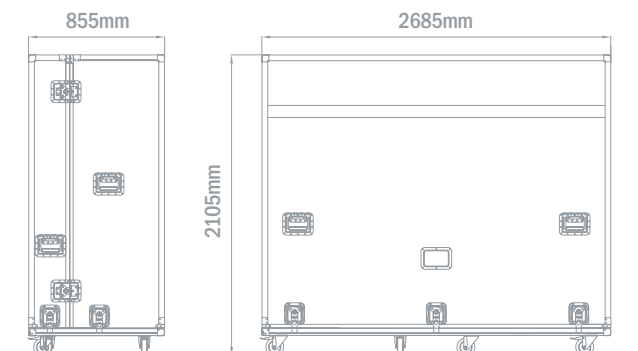

SCREENLIFTER FLIGHTCASE

Flight Case Dimensions	2685mm x 2105mm x 855mm
Flight Case Weight	647kg

SCREENLIFTER

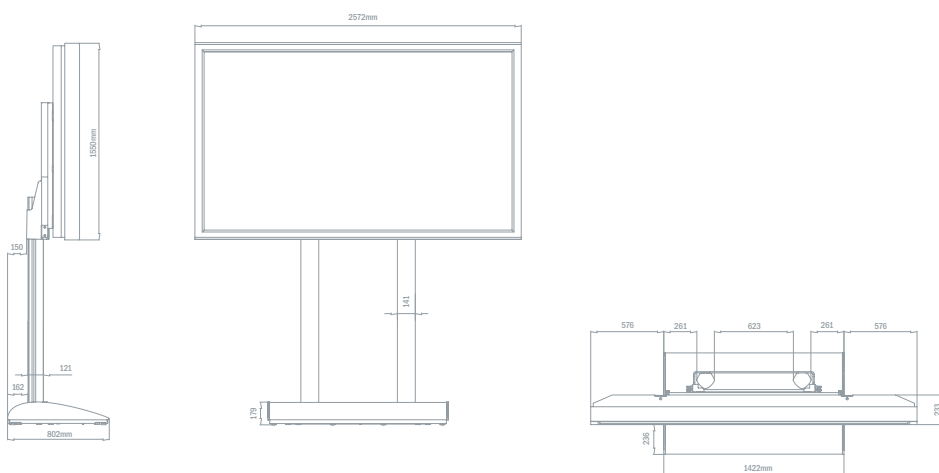

SCREENLIFTER

Dimensions (Screen + Screenlifter)	2572mm x 1793mm x 802mm
Max Height lower edge of screen (Landscape)	523mm
(Portrait)	N/A
Max Height of System (Landscape)	3073mm
(Portrait)	N/A
Rotation Angle of Screen	N/A
Weight (Screenlifter only)	205kg
Standard Colour	Aluminium